



LASER
TOOLS CO., INC.

**“Let Us
Make Your
Fixtures”**

The GRAVESTONE™ Quick Change Fixturing System

The GRAVESTONE™ work holding fixture is comparable to a horizontal milling center tombstone and fits any Haas HRT 160mm rotary platter. Increase productivity compared to conventional vertical milling center work holding methods. These fixtures are constructed of 7075-T6 aluminum and are available as a “DIY” template or a custom solution tailored to your needs.

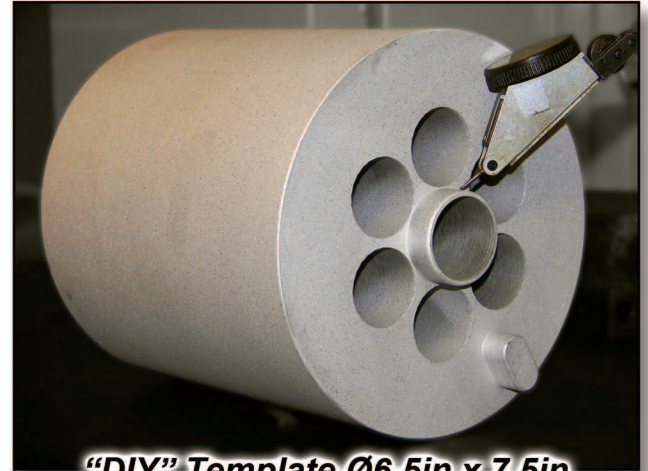

“DIY” Template Ø6.5in x 7.5in

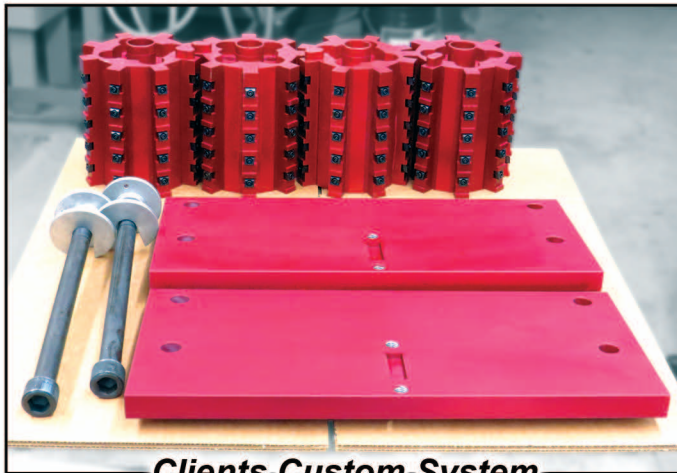

Clients Custom System

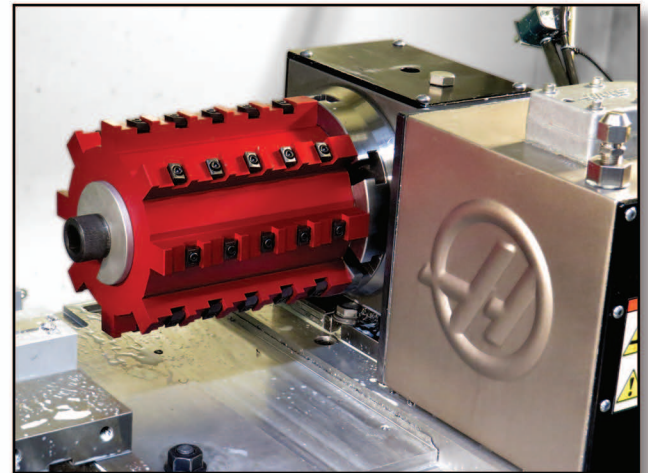

“What This Means To You”

- **Unattended Operation**
Maximize profitability.
Lower lead times.
- **Reduced Tool Changes & Minimum Part Swapping**
“Keeps the chips flying.”
- **Light Weight**
Easy to handle, no assistance needed.
- **Wear Resistant Hard Anodizing Available**
Extends the life of your investment.
- **Allows Operators to perform other tasks**
Operate Multiple Machines, Deburr, etc.

ORDER NOW!
1-800-598-5973

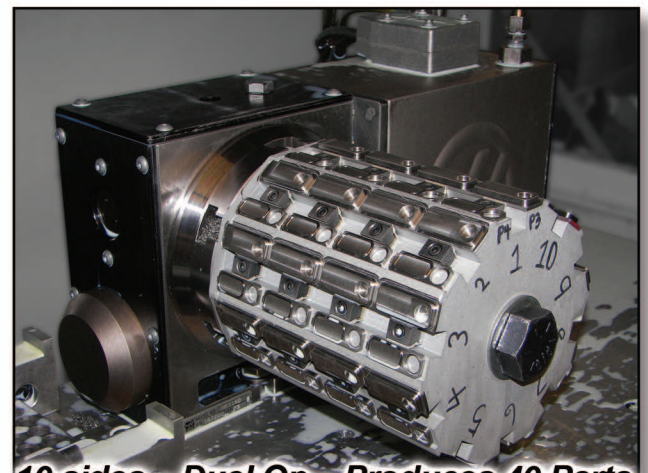

10 sides – Duel Op – Produces 40 Parts

NEW

LASER
TOOLS CO., INC.

**“Let Us
Make Your
Fixtures”**

**ORDER NOW!
1-800-598-5973**

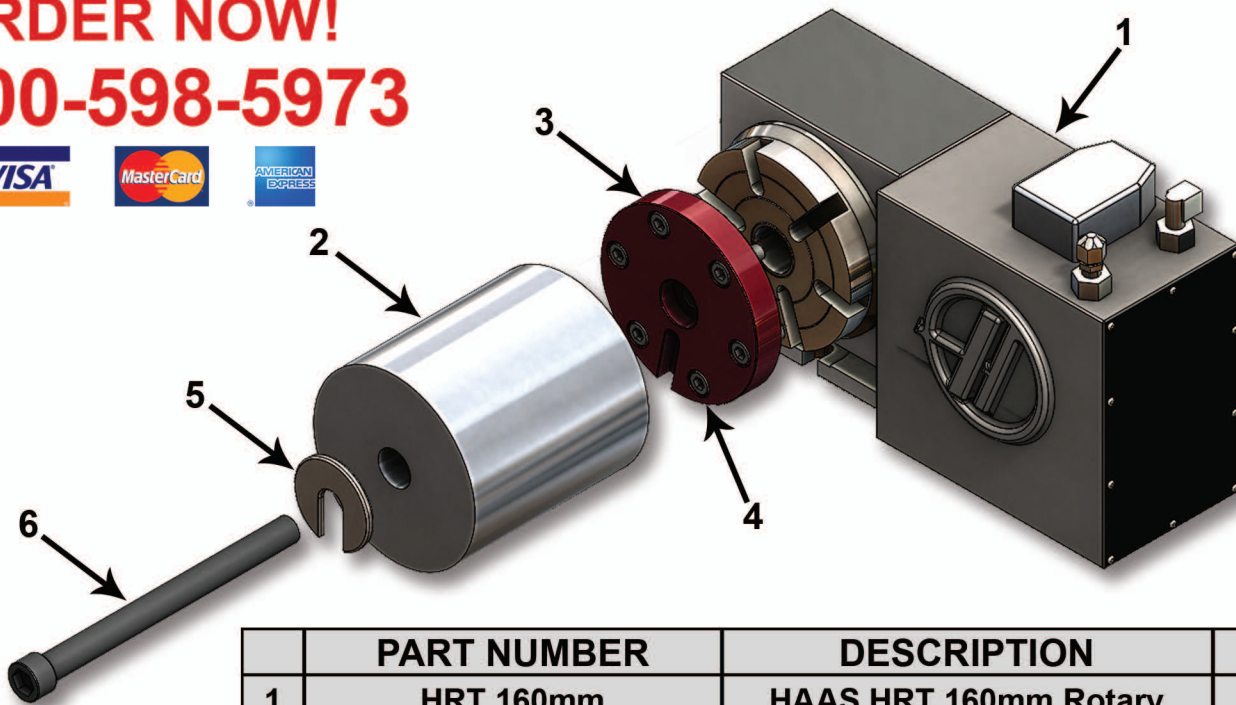

	PART NUMBER	DESCRIPTION	QTY.
1	HRT 160mm	HAAS HRT 160mm Rotary	1
2	Blank Fixture	Ø6.5 X 7.0 Cylinder	1
3	Adapter for Gravestone	Bolts to HRT 160mm Plater	1
4	Hex Bolt 513	1/2-13 X 1-1/4	6
5	U-Washer	Quick Change Washer	1
6	Hex Bolt 789	7/8-9 x 10in	1

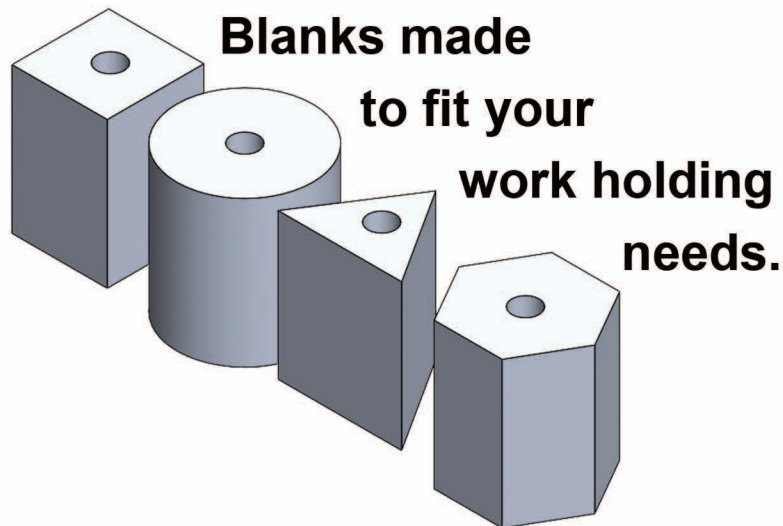

**“Don’t Own a
HAAS?”**

**“We will make an
adapter to fit
your rotary.”**